

TrueTouch™ Single-Touch Touchscreen Controller

Features

- TrueTouch™ Capacitive Touchscreen Controller
 - Supports Single-Touch Touchscreen Applications
 - Supports up to 45 X/Y Sensor Inputs
 - Supports Screen Sizes 8.5" and Below (Typical)
 - Fast Scan Rates: Typical 125 us per X/Y Crossing
 - High Resolution: Typical 480 x 360 for 3.5" Screen
 - Available in 56-Pin QFN Package
 - Seamless Transition up to Higher Function Multi-Touch Gesture and Multi-Touch All-Points-Addressable Devices
- Lowest Noise TrueTouch Device
- Highly Configurable Sensing Circuitry
 - Allows Maximum Design Flexibility
 - Allows Trade-Off Between Scan Time and Noise Performance
- Provides Maximum EMI Immunity
 - Selectable Spread-Spectrum Clock Source
- Powerful Harvard Architecture Processor
 - M8C Processor Speeds to 24 MHz
 - Two 8x8 Multiply, 32-Bit Accumulate
 - Low Power at High Speed
 - 3V to 5.25V Operating Voltage
 - Industrial Temperature Range: -40°C to +85°C
 - USB Temperature Range: -10°C to +85°C
- Full-Speed USB (12 Mbps)
 - Four Uni-Directional Endpoints
 - One Bi-Directional Control Endpoint
 - USB 2.0 Compliant
 - Dedicated 256 Byte Buffer
 - No External Crystal Required
- Flexible On-Chip Memory
 - 16K Flash Program Storage, 50000 Erase/Write Cycles
 - 1K SRAM Data Storage
 - In-System Serial Programming (ISSP)
 - Partial Flash Updates
 - Flexible Protection Modes
 - EEPROM Emulation in Flash
- Precision, Programmable Clocking
 - Internal ±4% 24/48 MHz Oscillator
 - Internal Oscillator for Watchdog and Sleep
 - 25% Accuracy for USB with no External Components
- Additional System Resources
 - I²C™ Slave, Master, and Multi-Master to 400 kHz
 - Watchdog and Sleep Timers
 - User-Configurable Low Voltage Detection
 - Integrated Supervisory Circuit
 - On-Chip Precision Voltage Reference
- Complete Development Tools
 - Free Development Software (PSoc Designer™)
 - TrueTouch Touchscreen Tuner
 - Full-Featured, In-Circuit Emulator and Programmer
 - Full Speed Emulation
 - Complex Breakpoint Structure
 - 128K Bytes Trace Memory
- Programmable Pin Configurations
 - 25 mA Sink on All GPIO
 - Pull Up, Pull Down, High Z, Strong, or Open Drain Drive Modes on All GPIO
 - Configurable Interrupt on All GPIO

Logic Block Diagram

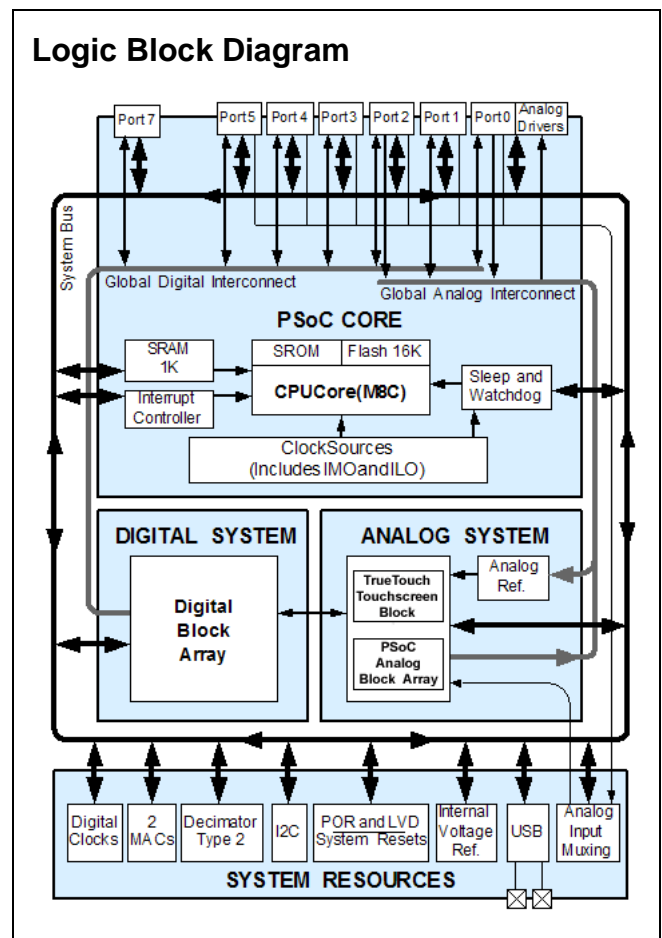

Document History Page

| Document Title: CY8CTST120 TrueTouch™ Single-Touch Touchscreen Controller | | | | |
|--|---------|-----------------|-----------------|-----------------------|
| Document Number: 001-46932 | | | | |
| Revision | ECN | Orig. of Change | Submission Date | Description of Change |
| ** | 2518134 | DSO/AESA | 06/18/08 | New data sheet |

Sales, Solutions, and Legal Information

Worldwide Sales and Design Support

Cypress maintains a worldwide network of offices, solution centers, manufacturer’s representatives, and distributors. To find the office closest to you, visit us at cypress.com/sales.

Products

- PSoC psoc.cypress.com
- Clocks & Buffers clocks.cypress.com
- Wireless wireless.cypress.com
- Memories memory.cypress.com
- Image Sensors image.cypress.com

PSoC Solutions

- General psoc.cypress.com/solutions
- Low Power/Low Voltage psoc.cypress.com/low-power
- Precision Analog psoc.cypress.com/precision-analog
- LCD Drive psoc.cypress.com/lcd-drive
- CAN 2.0b psoc.cypress.com/can
- USB psoc.cypress.com/usb

© Cypress Semiconductor Corporation, 2008. The information contained herein is subject to change without notice. Cypress Semiconductor Corporation assumes no responsibility for the use of any circuitry other than circuitry embodied in a Cypress product. Nor does it convey or imply any license under patent or other rights. Cypress products are not warranted nor intended to be used for medical, life support, life saving, critical control or safety applications, unless pursuant to an express written agreement with Cypress. Furthermore, Cypress does not authorize its products for use as critical components in life-support systems where a malfunction or failure may reasonably be expected to result in significant injury to the user. The inclusion of Cypress products in life-support systems application implies that the manufacturer assumes all risk of such use and in doing so indemnifies Cypress against all charges.

Any Source Code (software and/or firmware) is owned by Cypress Semiconductor Corporation (Cypress) and is protected by and subject to worldwide patent protection (United States and foreign), United States copyright laws and international treaty provisions. Cypress hereby grants to licensee a personal, non-exclusive, non-transferable license to copy, use, modify, create derivative works of, and compile the Cypress Source Code and derivative works for the sole purpose of creating custom software and or firmware in support of licensee product to be used only in conjunction with a Cypress integrated circuit as specified in the applicable agreement. Any reproduction, modification, translation, compilation, or representation of this Source Code except as specified above is prohibited without the express written permission of Cypress.

Disclaimer: CYPRESS MAKES NO WARRANTY OF ANY KIND, EXPRESS OR IMPLIED, WITH REGARD TO THIS MATERIAL, INCLUDING, BUT NOT LIMITED TO, THE IMPLIED WARRANTIES OF MERCHANTABILITY AND FITNESS FOR A PARTICULAR PURPOSE. Cypress reserves the right to make changes without further notice to the materials described herein. Cypress does not assume any liability arising out of the application or use of any product or circuit described herein. Cypress does not authorize its products for use as critical components in life-support systems where a malfunction or failure may reasonably be expected to result in significant injury to the user. The inclusion of Cypress’ product in a life-support systems application implies that the manufacturer assumes all risk of such use and in doing so indemnifies Cypress against all charges.

Use may be limited by and subject to the applicable Cypress software license agreement.